



Komet™ 19 Owner's Manual

PRECAUTIONS

TUBES ARE HOT! Make sure you allow the tubes in your amplifier to cool down before handling them. They are also made of glass and can easily break. Wear safety gloves and goggles when handling audio tubes.

DO NOT OPEN UP THE AMPLIFIER! There are no user serviceable parts inside. There are lethal voltages present even when unplugged.

NEVER: replace the Mains or H.T. fuse with a higher rated fuse. This will most certainly cause severe damage to your amplifier.

NEVER: use a shielded guitar or instrument cable as a speaker cable connection.

NEVER: operate any amp without a speaker load connected to the output jack(s).

ALWAYS: make certain that your AC power cable is unplugged when replacing any fuse.

ALWAYS: operate your Komet™ amplifier with the correct tube types listed in this owner's manual.

ALWAYS: use a three pronged, grounded AC power cable and always plug into a properly grounded outlet. Failure to do so may result in injury or death.

ALWAYS UN-PLUG YOUR AMPLIFIER WHEN YOU ARE DONE! This is to protect your amplifier from surges in electrical power, or transient voltage. The standard American home AC voltage is 120 Volts. Anything over this amount is considered transient and can damage electronic devices that are plugged into an AC outlet. Though power surges are brief and measured in nanoseconds, they can cause considerable or permanent damage to electronic equipment. Electrical surges can damage electrical equipment by burning or fusing internal wires or by the gradual degradation of a device's internal components. **The best way to prevent damage is to unplug your amplifier when not in use.**

NOTE: Devices such as refrigerators and air conditioners require large amounts of energy to switch motors and compressors on and off. Such devices can create surges in power that disrupt the steady flow of line voltage. Lightning, faulty wiring, downed power lines and faulty equipment at the power source (utility company) can all cause power surges as well.

ALWAYS: try to keep your amplifier and /or speaker cabinet in a climate controlled setting. Failure to do so can be problematic. The tolex on your amplifier head box cabinet can shift and shrink in the Summer, especially if you leave your amplifier for an extended amount of time in a sun heated vehicle, trunk, trailer, or an extremely hot and humid - un-air conditioned environment. This is due to the glue used to apply the tolex to the wooden head box cabinet. The glue can become slightly molten from excessive heat, which can make the tolex movable, expand and then shrink when cooled. Excessive heat can only cause this tolex situation and this **is not** covered under your Komet™ warranty.

IMPORTANT SAFETY INSTRUCTIONS

1. Read these instructions.
2. Keep these instructions.
3. Heed all warnings.
4. Follow all instructions.
5. Clean only with dry a cloth.
6. Do not block any ventilation openings. Install in accordance with the manufacturer's instructions.
7. Do not install near any heat sources, such as radiators, heat registers, stoves, or other apparatus (including amplifiers) that produce heat.
8. Protect the power cord from being walked on or pinched, particularly at plugs, convenience receptacles, and the point where they exit from the apparatus.
9. Only use attachments/accessories specified by the manufacturer
10. Unplug this apparatus during lightning storms or when not used for long periods of time.
11. Refer all servicing to qualified personnel. Servicing is required when the apparatus has been damaged in any way, such as a power-supply cord or plug is damaged, liquid has been spilled or objects have fallen into the apparatus, the apparatus has been exposed to rain or moisture, does not operate normally or has been dropped.
12. **CAUTION:** To disconnect the unit completely from the Mains, unplug the unit. Turning the power switch off does not completely disconnect the unit from the Mains.
13. Do not defeat the safety purpose of the polarized or grounding-type plug. A polarized plug has two blades, with one wider than the other. A grounding-type plug has two blades and a third grounding prong. The wide blade and the third prong are provided for your safety. If the provided plug does not fit into your outlet, consult an electrician for replacement of the obsolete outlet.
14. The unit shall not be exposed to dripping or splashing of liquids, and that no objects filled with liquids such as vases shall be placed on the unit.
15. **WARNING:** This is a **Class 1** apparatus. This unit should be connected to a MAINS socket outlet with a protective earthing connection.

EU ENVIRONMENTAL DIRECTIVES

RoHS This product is compliant with the EU Directive 2011/65/EU for the Restriction of the use of Certain Hazardous Substances in Electrical and Electronic Equipment. No lead (Pb), cadmium (Cd), mercury (Hg), hexavalent chromium (Cr+6), PBB or PBDE is intentionally added to this device. Any traces of impurities of these substances contained in the parts are below the RoHS specified threshold levels.

REACH This product is compliant with the European Union Directive EC1907/2006 for the Registration, Evaluation, Authorization, and Restriction of chemicals (REACH) and contains none or less than 0.1% of the chemicals listed as hazardous chemicals in the REACH regulation.

WEEE This symbol on the product or its packaging indicates that this product must not be disposed of with other waste. Instead, it is your responsibility to dispose of your waste equipment by handing it over to a designated collection point for the recycling of waste electrical and electronic equipment. The separate collection and recycling of your waste equipment at the time of disposal will help conserve natural resources and ensure that it is recycled in a manner that protects human health and the environment. For more information about where you can drop off your waste equipment for recycling, please contact your local city recycling office or the dealer from whom you purchased the product.

CE This product complies with the European Union Council Directives and Standards relating to electromagnetic compatibility EMC Directive (2006/95/EC) and the Low Voltage Directive (2004/10)

THANK YOU FOR PURCHASING THE KOMET™19 AMPLIFIER

The Komet™ 19 is a straightforward and easy to operate amplifier. The goal of this manual is to help you "*get acquainted*" with your Komet™ amplifier, and how to make use of its many capable sounds.

FRONT CONTROL PANEL LAYOUT (left to right):

1. **Input Jack:** accepts standard ¼ inch plug. Input impedance is 1 Megohm.
2. **Bright Switch:** three way selector switch. **Middle** position is off. **Down** position - bright. **Up** position - most bright.
3. **Volume Control:** adjusts (clockwise) the overall level and gain of the amplifier.
4. **Saturation Control:** a gain control that increases the guitar signal from natural clean into a smooth harmonic overdrive range. Please keep in mind that the effect of this control is interdependent with the setting of the amplifier's volume control.
5. **Tone Control:** adjusts (clockwise) the low to high end range of frequency equalization. Experiment with this control to find the settings that best suit your playing style.
6. **Pilot Light:** illuminates when power switch is in "On" position. The pilot light uses a type # 47 (6.3 Volt) light bulb. (See trouble shooting section for replacement instructions).
7. **Standby Switch:** allow the amp to warm up for **60** seconds before engaging the standby switch to the play position. This action allows for the tubes' filaments to heat up to the proper voltage required for operation. This procedure will prolong the lifespan of the amplifier's tubes.
8. **Power Switch:** engages the AC wall power to the amplifier.

BACK CONTROL PANEL LAYOUT (left to right):

1. **AC Input:** this IEC receptacle accepts standard DIN AC 16 gauge, three conductor power cable. All Komet™ amplifiers can be internally modified to operate on either **120V** or **240V**. Please inquire with Komet™ Amplification for conversion information.
2. **Mains Fuse Holder:** **2 Amp** "slow blow" fuse (a.k.a. MDL 2A - size: ¼ inch by 1 and ¼ inch) on **120V** model, **1 Amp** "slow blow" fuse on **240V** model. **CAUTION: ALWAYS UN-PLUG YOUR AC POWER CABLE FROM YOUR AMPLIFIER BEFORE REPLACING A FUSE.**
3. **H.T. Fuse** (High Tension): **½ Amp** or **500 mA** "fast acting" fuse (a.k.a. AGC 500 mA - size: ¼ inch by 1 and ¼ inch). **CAUTION: NEVER REPLACE A FUSE WITH A HIGHER RATED FUSE.** Using a fuse rated higher than the manufacturer's recommendation will **most certainly** cause severe damage to your amplifier.
4. **Output Impedance Selector:** set this selector according to the appropriate speaker impedance you are using. **4, 8, and 16 Ohm** settings are available.
5. **Speaker Output Jacks:** two, standard ¼ inch speaker jacks, wired in parallel, which will accommodate any standard quality speaker cable. **Note:** never use a shielded guitar cable for a speaker cable. You can severely damage an amplifier.
6. **Tube Chart:** Displays the placement of the power and pre amp tubes (V1 through V4).

TUBE CHOICES FOR THE KOMET™ 19

PRECAUTION: always allow the power and pre amp tubes to cool down before handling. They are made of glass and can easily break when mishandled. Wear safety goggles and heat protective gloves when handling hot tubes. **Never** remove or replace the power or pre amp tubes while an amplifier is on.

The stock power tubes (V3 and V4) are a matched pair of Sovtek® EL84/6BQ5s. This is a widely available and reliable power tube. The Mullard re-issue EL84/6BQ5 by Sovtek® is an excellent replacement upgrade.

The Komet™19 was designed and voiced to utilize current production audio vacuum tubes to their maximum potential. We prefer the Sovtek® 12AX7 LPS for the V1 and V2 positions. The LPS is an excellent sounding 12AX7 and are used in all Komet™ amplifier models. (continued)

Please note: you may find that some pre amp tubes, whether newly manufactured, used, or even n.o.s., may be too "**microphonic**" for the first gain stage (V1) of a Komet™ amplifier. A microphonic preamp tube is a condition in which a tube will absorb mechanical vibration and amplify it into the audible range. In this scenario, a tube can "**feed-back**", or give off a loud, high pitched squealing noise.

Feed-back can occur intermittently, even without an instrument plugged into the input of the amp. This does not mean that the tube(s) are completely unusable. One possible solution you can experiment with is moving the microphonic tube to the V2 phase inverter socket where microphonics are not as noticeable. The microphonic 12AX7 may be quieter in the V2 position as opposed to the V1 position.

Please note: a small amount of "**hiss**" is normal for high gain amplifiers. An excessive amount of hiss, especially when the volume control of the amplifier is all the way down and with no instrument plugged in the amplifier's input, usually denotes a bad pre amp tube. Some n.o.s. audio tube suppliers offer "**select**" or hand picked pre amp tubes, which are superior in all aspects of quality, especially when it comes to being quiet and non-microphonic.

Please note: your amplifier produces heat. Prolonged gigs, outdoor or non-climate controlled venues, only multiply that factor. We suggest after extended play - that you allow for a sufficient amount of time to pass - so as to let your amplifier cool down prior to moving or loading. This will help protect and extend the lifespan of the audio tubes and internal components from excessive vibration or damage.

Please pay close attention when extracting and installing the power and pre amp tubes. The pins must align perfectly into the tube's socket. Bent tube pins, especially when forced into a tube socket, can cause serious damage to an amplifier's tube socket pin inserts. This results **99%** of the time with the tube socket needing replacement. To avoid this contingency, we recommend that you purchase a miniature pinned, nine hole, pre amp tube pin straightener. These can be found on line from many vintage tube retailers. This easy to use device guarantees that your pre amp tube and EL84 power tube pins will be straight and aligned for socket insertion. **Please note:** Komet™ Amplification's limited lifetime warranty will not cover damage done to a tube socket's insertion pins from forced or accidental mis-alignment / and or bent / crimped insertion pins.

TUBE REPLACEMENT

A noticeable deterioration in your amplifier's overall sound is an indication of an imminent tube replacement. You may notice symptoms such as "**muddy**" or "**saggy**" power chords, a loss of tightness or "**punch**", a weak sounding treble and bass, and loss of certain sonic frequencies or note "**bloom**". We suggest that you first start by replacing your power tubes. Pre amp tubes can last a very long time, and do not necessarily need to be replaced as often as the power tubes. However, we do recommend that you have both the pre amp and power tubes properly tested by a technician between servicing.

BIASING THE KOMET™ 19

The Komet™ 19 is a cathode biased amplifier. An internal resistor sets the amplifier's power tube bias. A bias adjustment should not be necessary. To guarantee your amplifier will operate properly in conjunction with the supplied voltages and current draw of the Komet™ 19, we recommend that when you replace your power tubes, that you purchase a **matched** set of EL84/6BQ5s labeled by the manufacturer with a low **IP** number (or a low plate voltage / current draw number) or grade and labeled as well with a transconductance (Gm) matching numbers.

Having matched power tubes ensures that all of the power tubes will operate and react equally within the amplifier. Matched power tubes will also guarantee better harmonics, sonic performance and extended tube life. Most reliable and reputable audio tube vendors and n.o.s. tube dealers sell their power tubes in matched, output power or plate voltage / current draw, numerically rated sets.

You should be able to request a certain IP (plate voltage /current draw) grade or range from your tube vendor. Some tube vendors refer to their power tubes for their "break up" characteristics by labeling their sets with terms like: "**soft**", "**medium**" or "**hard**". Usually, power tubes labeled "**soft**" are the low plate current drawing type. Many vacuum tube vendors use their own numeric measurement system. Some examples: the Sovtek® EL84 grade for the Komet™19 is an IP number range from # **12** through # **15**. The original Groove Tube® rating scale for the Songwriter 30 would be a grade # **1** through # **3**. **Note:** the 12AX7 pre amp tubes in your amplifier are internally self biased and need no adjustment.

WARNING: Never remove any of the four EL84/6BQ5 power tubes in order to attempt cutting the power of the amplifier in half. The Komet™ 19's EL84 power tube circuitry shares only one cathode resistor. Removal of one or more of the power tubes will cause the other EL84s to catastrophically malfunction and fail.

Under-biased Power Tubes:

EL84/6BQ5 power tubes that are under biased, (or drawing too much current), will usually create the following symptom: a low, background "**hum**" sound coming from the amp, which may get louder as time passes. You should inspect the plates of the power tubes (the flat grey colored, metallic, square section inside the **center** of the power tube/s). Make sure your amplifier is on. **Do not** confuse the yellow / orange filament glow on the top and bottom of the power tubes for the center plates.

If the plates in the center of the tube are glowing a dull "**red**" or are "**cherry colored**" from the center, (see reference photo on following page), then the power tubes are under biased and **must be replaced with a lower (IP) plate voltage / current drawing** - set. If not replaced, they will fail and "short out" in short order, and the H.T. fuse will blow. Another sign of under-biased power tubes - the descriptive, colored lettering/labeling on the tube(s) has turned a bright, frosted white color, or occasionally - completely burned off.



SPEAKERS FOR THE KOMET™19

The Komet™19 is a big sounding amp. It is voiced for a sparkling clean sound at low volumes, and a smooth, dynamic - harmonic overdrive and strong midrange punch. *In our opinion*, these characteristics are best complimented with a closed back, (preferably vintage) **4 x 12** speaker cabinet. Our favorite reference speakers for Komet™ amplifiers in general are original coned, vintage 12 inch Celestion® speakers from the 1960's. You may come to a different conclusion, depending on your playing style and preferences.

A **2 x 12** cabinet, (open or closed back), is another excellent choice, but care should be taken to select speakers that can handle the power, low end, and attack. The Komet™ Amplification speaker cabinet lineup is another excellent option. Please see our website www.kometamps.com for full speaker cabinet information. Whichever cabinet you do use, make sure you **set the impedance selector correctly**. If you use two cabinets, keep in mind that the outputs are in parallel. This means that if you are operating the amplifier on two, 16 Ohm cabinets, you must set the amplifier's impedance selector to the 8 Ohm setting. If you operating on two, 8 Ohm cabinets, set the selector to 4 Ohms. We do not recommend using two, 4 Ohm cabinets. Speaker wiring diagrams are located at the end of this owner's manual.

An Important Note on Speaker Cables, Cabinets and Speakers: It is crucial that you always maintain a solid, un-interrupted signal between your amplifier and speaker cabinet. Sub-standard speaker cables as well as sub-standard cabinet wiring can become problematic, intermittent and fail over time. This can possibly causing damage to your amplifier and speakers. We recommend that you use quality brand speaker cables (18 gauge is sufficient) made with quality male input plugs. The speaker cable plugs should be soldered directly on to the internal speaker cable wires. Using a quality made speaker cable will ensure a tight fit from the amplifier's speaker jacks to the speaker cabinet.

Your speaker cabinet should be equipped with a quality brand input jack. We prefer and use the Switchcraft® #11 mono input on our cabinets, amplifiers and vintage repairs. Many vintage speaker cabinets from the 1960's to 1970's used the #11 jack. It is reliable, solid and time tested. Many modern made brand speaker cabinets use the Switchcraft® #11, but not all. Some manufacturers have their speaker jacks panel mounted on the back of their cabinets which incorporate an internal circuit board on which the jacks are soldered. This type of system is not designed for a type #11 jack, and conversion to the #11 can be very tedious. All electrical work should be performed by a professional and knowledgeable technician.

We also strongly urge you to inspect and make sure that all of your internal speaker cabinet wire leads are soldered at the speaker jack and soldered at the speaker terminals. We **do not** recommend using the "slide on" type gripping speaker wire terminals. These grip type terminals loosen over time causing an interruption or failure of the signal. These recommendations help guarantee a solid, **un-interrupted signal** from the amplifier to the speakers at all times.

Please note: Komet™ Amplification recommends using resistive load attenuation devices in conjunction with any Komet™ amplifier and speaker cabinet. Please see our website www.kometamps.com for further information on the Komet™ Airbrake™ attenuator. The Komet™ Airbrake™ owner's manual is also located at the end of this manual.

TROUBLESHOOTING

When troubleshooting a problem, we recommend that you remove all effects pedals and only go direct with your guitar and guitar cable into the amplifier. Also, remove any attenuation device from your amplifier to speaker cabinet signal chain. This way you can easily and quickly rule out or discover if your amplifier is the source of the problem.

Pilot Light Not On:

Check to see if the amplifier's AC cable is plugged in at wall and plugged in at the IEC connection on the back panel of the amp. Make sure the DIN AC cable plug is securely inserted into the IEC AC input connection, and pushed in all the way.

Check the type **47** pilot light bulb. It may be burned out. For bulb replacement, gently turn the jewel lens cap counterclockwise and remove. Using the tips of your fingers, gently push and turn the exposed bulb counterclockwise, extract bulb and replace. **Note:** your amplifier will continue to operate with no problem with a shorted bulb or with no bulb at all.

Check the **2** amp "slow blow" AC supply "Mains" fuse to see if it is blown. Replace the blown fuse with a new **2** amp "slow blow" (a.k.a. MDL 2A 250V) or a **1** amp "slow blow" for a 240V model. **ALWAYS** - make certain that your AC power cable is unplugged when replacing any fuse.

Mains Fuse - "blowing":

Unplug amplifier from the wall AC. **Remove the power tubes** (see precautions section). Install a new **2 Amp "slow blow"** fuse (1 Amp "slow blow" 240V). Plug into the wall AC and turn the amp on (with **no** power tubes in the sockets).

Should the mains fuse continue to "blow", your amp will need to be serviced. If the fuse **does not** "blow", and the amp lights up, turn amp off, and install a **new** set of matched EL84 power tubes. Turn the amp back on. If the fuse does not blow, play the amp and monitor.

Amp Lights Up - No Sound:

Check the speaker connection at back of amp and at the input of the speaker cabinet. Bypass all pedals and effects and plug your guitar into only the amplifier. Check the guitar cable and / or try another guitar.

Check the power and the pre amp tubes and make sure that they are installed correctly and that the filaments within each tube are lit. **Note:** sometimes audio tubes can look operational - (with the filaments lit) - but be defective in not passing signal. This is rare, but can occur.

Check / test / replace - the **H.T.** fuse for continuity with a digital Ohm meter. It may be blown.

Amp is making a "Humming", "Hissing", "Feedback" or "Crackling" - sound:

This is most likely a bad pre amp tube. Pre amp tubes can develop problems over their life span. They may be operating flawlessly, and they may also test fine on a tube tester, but for what appears like for no reason, can suddenly begin to make a "**hissing**" or a "**crackling**" sound. They can begin to feedback or have microphonic or "**ringing**" symptoms. (See previous section titled: ECC 83, 12AX7, 7025, and CV4004), or develop filament "**humming**" - which is a low background hum, often mistaken for a problematic filter cap. Filament "humming" is much more common with new, modern available pre amp tubes. Unfortunately, you will most likely have to replace one of more of your pre amp tubes with any of these problems. This is another reason we stress purchasing n.o.s. tubes - they are less likely to "go bad".

Fluorescent and neon lights, rheostat wall dimmers, and some appliances may cause your amp to contain a "**hum**" or "**buzz**" sound. An internally shorted guitar cable or using a speaker cable for a guitar cable can also create a "**buzz**" sound through your amp.

Over time, the input jack may occasionally make a "**crackle**" sound when you extract your instrument cable from the front panel of your amp. This is usually due to a dust / contaminate build up on the input jack's ground shunt. This would require that the inside of the input jack be cleaned professionally. We recommend using DeoxIT® Gold G5.

Amp sounds "spongy" or "sputtering":

A "spongy" or "sputtering" - weak response from your amp can be one of two things. Under normal operating conditions, this symptomatic sound can be the result of "weak" power tubes, *i.e.* power tubes that have reached their operational lifespan. You may also notice this symptom when the volume control and saturation control are completely "dimed" out 100%, even with new power tubes. This is a result of **both** the power tubes and output transformer reaching complete saturation and is part of the circuit design. Backing off each control a small degree will re-align the signal path.

TUBE REPLACEMENT FOR THE KOMET™19

Before you install your tubes, please read the last paragraph from the section: **TUBE CHOICES FOR THE KOMET™ AMPLIFIER**

Unscrew (in small increments) the two, back panel insertion screws. Remove the back panel evenly with two hands. Use the reverse instructions when installing the Komet™19 head back panel. You will find the tube placement chart on the back panel of you amp. There are four tube sockets in total. These sockets are miniature nine pin pre amp tube socket types. Follow the placement of the four tubes by referring to the tube chart. Make sure the amplifier's tubes have cooled down sufficiently before handling the amplifier's tubes. V1 and V2 are the 12AX7 pre amp tubes. V3 and V4 are the EL84/6BQ5 power tubes. The tubes are secured to the tube socket by wire retainers that easily slide back and on each tube.

(
Note: we recommend that you replace one tube at a time as not to accidentally entangle each tube's wire retainers. **Caution:** always use a tube glove when handling hot tubes.

Gently install each tube in the correct corresponding tube socket. Please note each tube's pin configuration must be properly and perfectly aligned with the tube socket for installation. Do not force a tube into its socket. If correctly aligned, it should easily install into the socket.

Note: both the power and pre amp tubes are secured to the tube sockets by wire retainers that easily slide back and on each tube. We recommend, during a tube replacement, that you replace one tube at a time - as to not accidentally entangle the wire retainers.

SPECIAL INSTRUCTIONS FOR THE KOMET™19 COMBO

The K19 combo, **as with any back panel mount combo**, will be prone to microphonic pre amp tube problems over time. This is due to the construction and nature of the amplifier mounting. We recommend, when replacing tubes, purchasing pre-tested (for microphonics) pre amp tubes from a reputable tube dealer.

TUBE REPLACEMENT FOR THE KOMET™19 COMBO

The following information is for the more mechanically advanced user. Please bring your combo amp to a qualified technician if you do not feel comfortable with the following procedure. Unplug amp from the wall. Make sure the tubes of the amp have cooled down sufficiently before handling. **Note:** always wear a tube glove and safety glasses when handling audio tubes.

Lay the combo down face forward on a flat, clean soft surface like a carpet or on the floor protected by a thick towel.

Unplug the speaker cable and AC power cable from chassis. Un-screw and remove the **six** (three per side) back panel screws and washers.

!! WARNING !! Do not un-screw and remove the four, larger chassis mounting bolts. Doing so will release the amp chassis causing internal damage.

After you have un-screws the **six**, smaller (three per side on back panel) - gently extract the panel mounted chassis with two hands carefully positioned from under the chassis. Be careful not to grip or disturb the power and pre amp tubes.

Place the panel mounted chassis on a safe, flat surface and refer to this manual for the tube extraction and installation procedure. Install following the reverse of the chassis extraction procedure.

SERVICING

We are very confident that your Komet™ amplifier is one of the most reliable amplifiers ever built. A combined experience of many decades of amp design and service has been applied to the construction all Komet™ amplifier models. We have been inside thousands of amps and we have seen every kind of problem that can occur. Great care has been taken to anticipate and prevent such problems in your Komet™ amplifier. Every part and component in this amplifier has been carefully chosen for its specific performance. Some parts are proprietary or hard to find. We do not recommend replacing any of the internal components with generic parts from different manufacturers.

We also recommend that you bring your Komet™ amplifier to only a qualified service technician, especially if you should feel un-comfortable changing / installing audio tubes. Should your Komet™ amplifier ever need servicing or repair, please make arrangements with us to have your amp shipped back to Komet™ Amplification.

CLEANING

We recommend cleaning your head box / tolex with a slightly damp, warm cloth towel. **Please be very careful** when cleaning the front panel of your Komet™19 head box. The points of the plexi glass triangle Komet™ logo could possibly catch on a cleaning cloth. We recommend that you clean the triangle Komet™ logo starting from the center of the logo - to the outer edges of the amp. Repeat procedure always from the center. Avoid using T-shirts or cloths that contain graphics or embroidery. They may scratch some surfaces of your amp. We prefer using a microfiber cleaning cloth for the logo, control panels and metal surfaces.

SPECIFICATIONS KOMET™19 HEAD

- **Dimensions:** 17 ¼ " (length) X 9 " (depth) X 8 ½ " (height) - with feet
- **Weight:** 25 lbs.
- **Power:** 19 Watts RMS - (19 clean watts measured before distortion)
- **Tubes:** 2 - 12AX7 2 - EL84 / 6BQ5
- **Mains Fuse:** 2 Amp "Slow Blow" a.k.a. MDL 2A 250V (1 Amp / 240V operation)
- **H.T. Fuse:** ½ Amp "Fast Acting" a.k.a. AGC 500mA 250V (½ Amp a.k.a 500mA)

SPECIFICATIONS KOMET™19 COMBO

- **Dimensions:** 20 " (length) X 10 ¼ " (depth) X 19 " (height) - with feet
- **Weight:** 53 lbs. - (with G12H30 speaker & chassis)
- **Power:** 19 Watts RMS - (19 clean watts measured before distortion)
- **Tubes:** 2 - 12AX7 2 - EL84/6BQ5
- **Mains Fuse:** 2 Amp "Slow Blow" a.k.a. MDL 2A 250V (1 Amp / 240V operation)
- **H.T. Fuse:** ½ Amp "Fast Acting" a.k.a. AGC 500mA 250V (½ Amp a.k.a 500mA)

A FINAL WORD

Your Komet™ amplifier was designed to be played and enjoyed. By virtue of its unmatched quality, it will free you from thinking about your equipment and concentrate on the very thing that matters: **your music**. The Komet™19's responsiveness, musicality and immediacy - places you in charge of your sound. It can handle a small club performance situation with ease and is voiced to cut through the band mix.

Give yourself and your new amp a little time to get to know each other. No matter how good it sounds right out of the box, your amp will break in and improve tremendously after being played over time. The harmonic complexity will continue to improve; the tone will sweeten up and become even more fluid and resonant. Have fun!

Thank you for purchasing our product.

Michael Kennedy
Holger Notzel
Co-owners
Komet™ Amplification

CONTACT

Komet™ Amplification
1865 Dallas Drive
Baton Rouge, LA 70806-1454
(225) 926-1976
Email: info@kometamps.com

Website: www.kometamps.com
Facebook: <https://www.facebook.com/pages/Komet-Amplification/739410886107995>
Tumblr: <http://kometamplification.tumblr.com/>
Twitter: <https://twitter.com/kometamps>

Komet™ Warranty information located at end of owner's manual.

Komet™ Speaker Wiring Diagrams

Single 12" 16 Ohm Speaker

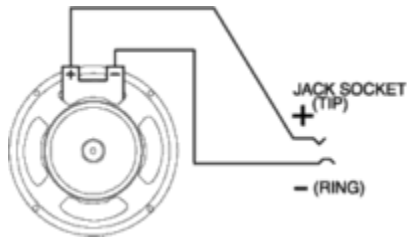

2 X 12" 8 Ohm Speakers in series for 16 Ohms

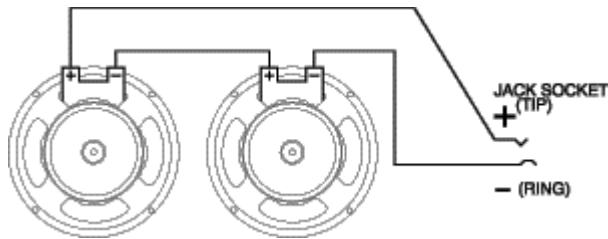

4 X 12" 16 Ohm Speakers in series / parallel for 16 Ohms

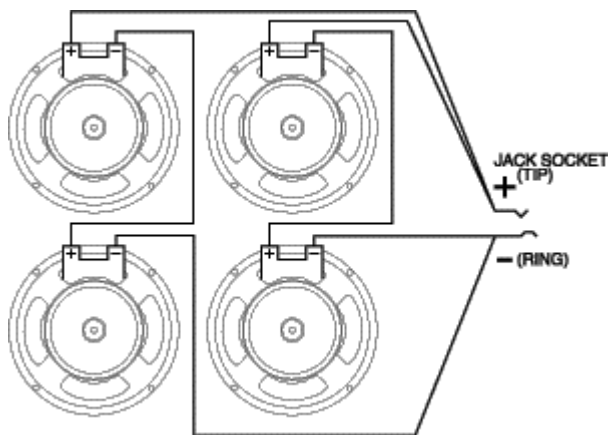

Note: Komet™ Amplification recommends using a **16 Ohm** load with their amplifiers for the best sonic results.



Komet™ Airbrake™ Manual

The Komet Airbrake™ Users Manual

The Komet™ Airbrake™ is a resistive load power attenuator, which connects between an amplifier's speaker output jack and a speaker cabinet. It allows the user to "turn up" the amplifier's volume, utilizing the amplifier's harmonically rich output stage distortion, while reducing the signal sent to the speakers. This lowers the amplifier's overall sound pressure level and is useful when high volume is not required.

All power attenuators by design reduce the interaction between an amplifier's output stage and the speakers, which is a critical part of the sound and feel of a tube amp. An attenuator can change the human ear's perception of the frequency spectrum by reducing the sound pressure level. Accordingly, there is no power attenuator that does not change the overall sound of an amplifier.

The Komet™ Airbrake™ sounds very natural and "transparent" at reasonable levels of attenuation. It allows the user to bring the level of a 50 / 60 Watt Komet™ amplifier down to that of a "cranked" 20 to 25 - watt amplifier, all the while retaining its distinct voice and dynamics. It is therefore best suited to match Komet™ amplifiers to a smaller room, or in a quieter playing setting.

Features of the Komet™ Airbrake™:

- operates on **8 Ω** or **16 Ω** speaker loads only.
- designed for a maximum power handling capability of **100 Watts**.
- five graduated attenuation settings via a six position rotary switch.
- **3dB** drop in first step of attenuation, approx. **1.7dB** each step after.
- the first (12 o'clock) position of the six position rotary switch is a true bypass setting (under no attenuation).
- one input, two parallel output jacks.
- line level signal out control.

Using the Komet™ Airbrake™ Power Attenuator:

You will need two, quality constructed, standard speaker cables. At the bottom of the Komet™ Airbrake™, below the Komet™ logo, you will find three input jacks arranged in a triangle formation. The top input jack (of the triangle formation) is the Airbrake's™ input. Connect one speaker cable from one of the amplifier's speaker outputs into the top input of the Komet™ Airbrake™. **Note:** (see last page for descriptive layout).

The bottom two jacks of the triangle formation are the two parallel outputs. Connect the second cable from one of the two Komet™ Airbrake™ outputs into the speaker cabinet input. If you only use one speaker cabinet, you may plug it into either one of the two, bottom output jacks on the Komet™ Airbrake™. **Note:** (see last page for descriptive layout).

Set the amplifier's impedance selector according to the impedance of the cabinet used. Remember to always use dedicated speaker cables of a sufficient gauge (we prefer 18 gauge) for both connections. **WARNING:** Never use instrument (guitar) cable as a speaker connection. By doing so will cause damage to the amplifier.

If you plug two speaker cabinets into the Komet™ Airbrake's™ parallel output jacks, make sure both cabinets or both speaker loads are rated at 16Ω. Keep in mind that the combined load of both cabinets or both speaker loads will be 8Ω. Set your amplifier's impedance selector accordingly to 8Ω.

Do not use two, 8 speaker cabinets. The combined load will be 4Ω, which is below the Komet™ Airbrake™ 8/16 Ohm operating range. For the same reason, do not use two 4Ω cabinets. Never combine two cabinets of different impedance ratings (for example an 8Ω cab and a 16Ω cab).

The line level signal out control is the cream colored knob located at the top of the Komet™ Airbrake™. The line level output jack is located to the right of the cream colored control knob. The line level signal out feature allows the user to send the un-attenuated signal from the amplifier under attenuation, into another amplifier, say one with reverb or tremolo, or send a signal to a recording or mixing console, or can be used to send the signal to a wet/dry rig. Make sure you use a quality constructed shielded instrument / guitar cable for this signal sending portion of the device.

If you use the line level signal out control to send a signal to a P.A. (public address) system, make absolutely sure that the level control is set and not disturbed while in use. You could possibly damage the P.A. system if the volume level/control knob were to be drastically raised or quickly "turned up" while in use.

Important:

We recommend that if you intend on using your Komet™ Airbrake™ in conjunction with much older, **vintage amplifiers**, that you set your vintage amplifier's impedance selector to 8Ω for the first step of attenuation (or the first click of the rotary switch), regardless of an actual 16 Ohm impedance of the speakers or cabinet used. If your amp and speaker load is 8Ω, set the impedance selector to 4Ω in the first step of attenuation. This precaution will lower the current flowing within the output tubes under full power. We also recommend this same action with EL84/6BQ5 powered amplifiers. Set the impedance selector of your vintage amplifier according to the speaker impedance being used in any other step of attenuation past the first click.

We recommend that you do not use the Komet™ Airbrake™ with a 100 Watt plus rated amplifier for **very long, extended periods at very high volume levels** (or with the volume controls “dimed out”). This is because the Komet™ Airbrake™ is a 100 Watt rated device. Any 100W amplifier can surpass its 100W RMS rating when cranked way up. This could possibly over-heat the attenuator causing damage to one or more of the load resistors.

Note: The Komet™ Airbrake™ will increase it's ability to handle an amplifier's wattage as the attenuation level increases. The maximum load capability for the Komet™ Airbrake is **200 Watts** under full attenuation. You should not have a problem using the Komet™ Airbrake with a 100W amplifier, but it is always best to operate your 100W amplifier and attenuator within reason.

Final note:

The Komet™ Airbrake™ power attenuator reduces volume by converting the amp's excessive power into heat. The device will get very warm, even hot, during use. Please make sure you place the unit in a well ventilated area and never have it covered up. The Komet™ Airbrake™ was designed for optimum performance with Komet™ and Trainwreck® amplifiers. The Komet™ Airbrake™ will work equally well with most other manufacturer's amplifiers, but Komet™ Amplification only guarantees safe operation with Komet™ and Trainwreck® amplifiers.

A Special Note on Speaker Cabinets and Speakers: we recommend that you use quality speaker cable with quality brand male plugs. This is to guarantee a tight fit to the speaker jacks and cabinet. We prefer the Switchcraft® #11 mono input. We also recommend that your speaker cabinet wire leads are directly soldered to the speaker terminals instead of using the "slide on" gripping terminals. (See special note in the Speaker Cabinet section of this manual).

The Komet™ Airbrake™ Layout

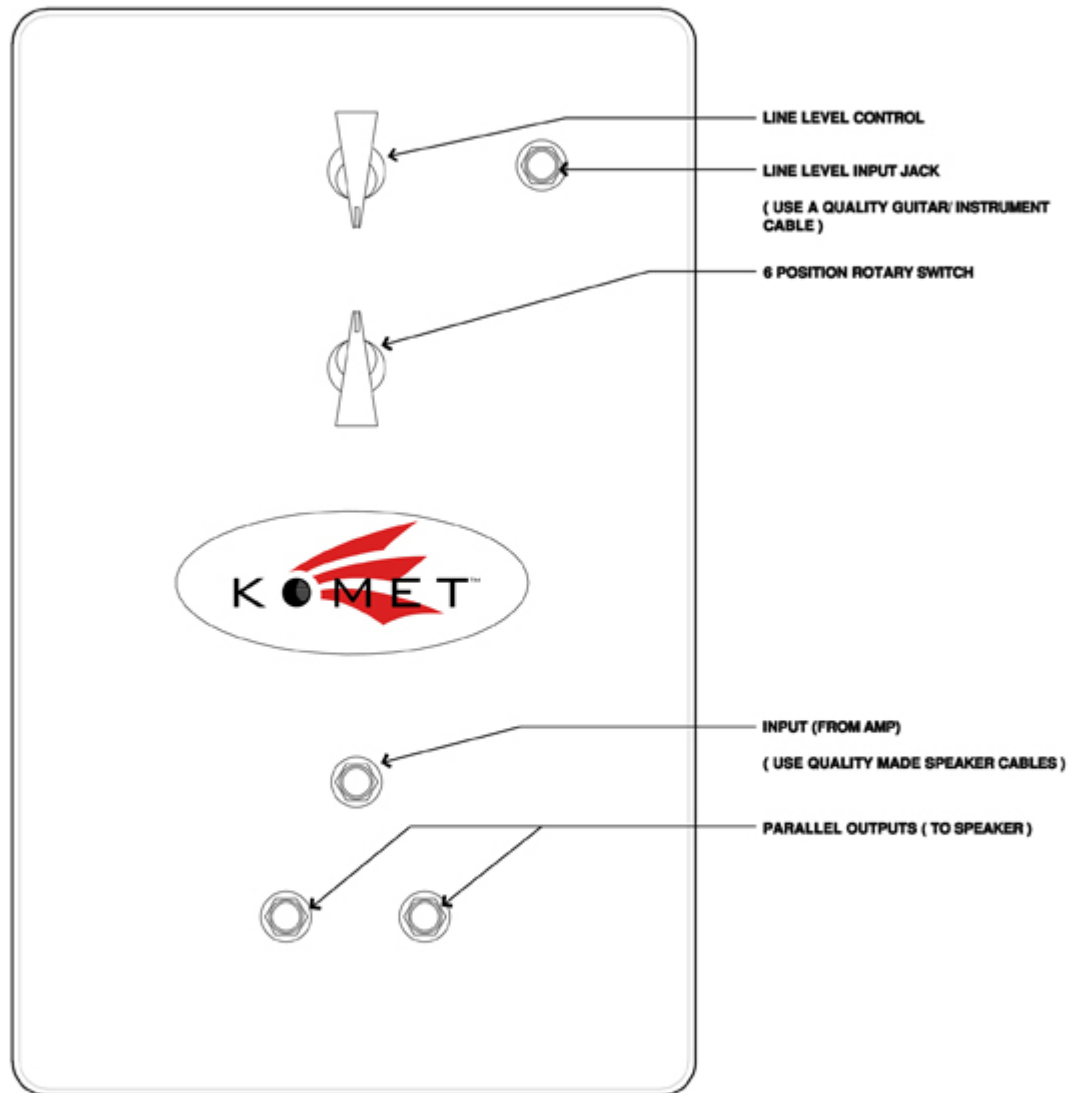

KOMET™ AMPLIFICATION'S WARRANTY

This warranty shall be void and of no force of effect in the event a covered product has been modified in design or function, or subjected to abuse, misuse, (which includes operation of amplifier with incorrect power and pre amp tube types), mishandling or unauthorized repair. Further, product malfunction or deterioration due to normal wear is not covered by this warranty. This includes the factory installed audio tubes and the amplifier's tube sockets. **Note:** any transformer failure will require a full inspection / diagnostic by the OEM transformer manufacturer for the cause of failure. Komet™ Amplification will not warranty Komet™ Amplification warrants their amplifiers to be free from defects in materials and workmanship for a (2) two year period. Komet™ Amplification will repair or replace any part there of which, upon inspection by Komet™ Amplification, is found to be defective in materials or workmanship. As a condition to the obligation of Komet™ Amplification to repair or replace such a part, the product must be returned to Komet™ Amplification with a copy of the original and dated sales receipt from the authorized Komet™ dealer. Komet™ Amplification's warranty is only applicable to the original owner of the amplifier. Warranty is not transferable.

The Proper Return Authorization must be obtained from Komet™ Amplification in advance of a return. Please call or e-mail Komet™ Amplification to receive authorization for warranty repair. All returns must be accompanied by a written statement setting forth the name, address, and daytime telephone number of the owner, together with a brief description of any claimed defects. Parts or product for which replacement is made shall become the property of Komet™ Amplification. The customer may be responsible for all costs of transportation and insurance, both to and from Komet™ Amplification, depending on result of inspection and validation of warranty request. Customer may be required to prepay such costs.

Komet™ Amplification shall use reasonable efforts to repair or replace any part covered by this limited warranty within thirty days of receipt. In the event repair or replacement shall require more than thirty days, Komet™ Amplification shall notify the customer accordingly. Any output transformer found (by the OEM transformer manufacturer) to be damaged from being overstressed or internally compromised by an attenuation device.

Warranty Exclusions and Limitations: Notwithstanding the foregoing, all warranty claims are excluded if:

Warranty Exclusions and Limitations: Notwithstanding the foregoing, all warranty claims are excluded if:

- i. the Product(s) is damaged or destroyed due to the effects of force majeure, including but not limited to: Acts of God, flood, fire; Acts of War, government authority, acts of terrorism, riots, explosions, embargo; Labor difficulty, strikes, breakdown of machinery or equipment, accidents; Shortage or inability to obtain raw materials, equipment, fuel, power, transportation; or Any cause beyond KOMET's reasonable control or due to environmental influences such as wind, hailstones, snow, frost, etc.

(continued)

- ii. the Product(s) is damaged from abuse, misuse, improper installation, or neglect;
- iii. the Product(s) is altered or appears to have been attempted repair by unauthorized personnel;
- iv. if the Product(s) has been modified in any way; or if a defective product has remained in use, resulting in consequential damage to the Product(s).

SHIPPING INSTRUCTIONS

Note: Komet™ Amplification highly recommends that you review all packaging, insurance requirements, and shipping recommendations of the shipping company you intend to use.

Komet™ suggests using a: **30 X 15 X 15** foam injected, **300lb.** test, corrugated cardboard shipping box.

Komet™ also suggests having your amplifier professionally packaged to ensure safety.

Shipped amplifiers should be insured for at least the full value of the amplifier.

Please **do not** return ship your amplifier with the AC power cable.

We recommend you bubble wrap and box your vacuum tubes, especially if they are n.o.s.

We are a commercial address. Please check any corresponding box on shipping label.

Please do not return ship your amplifier for "Home Delivery" service or Saturday delivery.

Please do not send for early morning (before 9:00 A.M.) delivery. We prefer afternoon delivery.

Note: Komet™ Amplification will not be held responsible for any Komet™ amplifier, amplifier component, or contents, damaged or lost during shipping to Komet™ Amplification. Komet™ Amplification will not be held responsible for any damage or loss of an amplifier due to improper packaging or labeling by the customer or packager. Any and all damaged or lost packages and their contents in which claims are filed for damage via shipping to Komet™ Amplification are between customer and shipper. Komet™ Amplification will do their absolute best to help any customer with a shipping insurance claim.

Our address:

Komet Amplification, L.L.C.
1865 Dallas Drive
Baton Rouge, La. 70806-1454
(225) 926-1976

E-mail: info@kometamps.com